



## Color CCD Camera

# WAT-250D2

## Operation Manual

This Operation Manual covers safety, camera functions, installation and the correct operating procedure for the WAT-250D2. First, we ask you to read this Operation Manual thoroughly, then install and operate the WAT-250D2 as advised. In addition, for future reference, we also advise safekeeping of this manual.

Please contact the distributor or dealer from which the WAT-250D2 was purchased, if you do not understand the installation, operation or safety instructions laid out in this manual. Not understanding the contents of the Operation Manual sufficiently may cause damage to the camera.

## Guide to the Safety Symbols

The definitions of the symbols used in this operation manual are:

When you do not adhere to or take notice of the "Danger" sign, it may lead to a serious accident such as death or injury caused by fire or electric shock.

When you do not adhere to or take notice of the "Warning" sign, it may cause severe damage such as a physical injury.

When you do not adhere to or take notice of the "Caution" sign, it may incur injury and cause damage to peripheral objects in the immediate surroundings.

## Cautions for Safety

The WAT-250D2 is designed to be used safely; however, it may lead to a physical accident caused by fire and electric shock if not used correctly. Therefore, please keep and read the "Cautions for safety" below for protection against accidents.

**Do not disassemble and/or modify the WAT-250D2.**  
**Do not operate the WAT-250D2 with wet hands.**

**Use a stabilized power adaptor designed for DC+12V±10%, with a current capacity of more than 250mA for the WAT-250D2.**

The recommended voltage is DC+12V±10%.

**Do not expose the WAT-250D2 to wetness or high moisture conditions.**

The WAT-250D2 is designed and approved for indoor use only. The WAT-250D2 is not water-resistant or waterproof. If the location of the camera is outdoors or in an outdoor like environment, we recommend that you use an outdoor camera housing.

**Protect the WAT-250D2 from condensation.**

Keep the WAT-250D2 dry at all times during storage and operation.

Should the camera not work properly, switch off the power immediately. Then check the camera according to the "Problems and Trouble shooting" section.

**Avoid the striking of hard objects or dropping the WAT-250D2.**

The WAT-250D2 uses high quality electrical parts and precision components.

**Do not connect any power supply directly to the video out terminal of the unit.**

Do not connect the WAT-250D2 with any monitor using a video/power single transmission terminal. The WAT-250D2 is not designed for use with this type of equipment. We also advise you to read the operation manual of the monitor you plan to use before any connections are made.

**Do not install the WAT-250D2 in a position subject to direct sunlight.**

Sunlight shinning directly onto the WAT-250D2 lens can cause damage to the CCD.

**Select a stable place for installation of the WAT-250D2.**

Use a support of durable strength around an installation position on a ceiling or wall when a camera stand or tripod is used.

**Do not move the WAT-250D2 with the cables connected.**  
Before moving the WAT-250D2, always remove the video cable and power cable from the rear of the camera first.

**Avoid using the WAT-250D2 near any strong electromagnetic field.**

After installing into main equipment, if the WAT-250D2 is exposed to electromagnetic waves causing the monitored image to become distorted, we recommend the camera be shielded by appropriate protective casing.

## Problems and Trouble Shooting

If any of the following problems occur when using the WAT-250D2,

- An optimal picture cannot be obtained, after checking that all the cables and connections are correctly in place
- Smoke or any unusual odor emerges from the WAT-250D2
- An object becomes embedded or a quantity of liquid seeps into the camera housing
- More than the recommended voltage or/and amperage has been applied to the WAT-250D2 by mistake
- Anything unusual occurring to any equipment connected to the WAT-250D2

**Disconnect the camera immediately according to the following procedures:**

- Switch off the main power supply to the camera.
- Remove the power and video cables connected to the WAT-250D2.
- Contact the distributor or dealer from which the WAT-250D2 was purchased.

## About EMC

The WAT-250D2 is in conformity with EMC test standards carried out by authorized organizations in Japan.

NTSC FCC Part15 class B  
P A L EN61000-6-3/EN50130-4

Do not modify the WAT-250D2. A modified camera may not conform to EMC test standards.

## Contents

Using the contents figures below, check to make sure all parts are present before use.

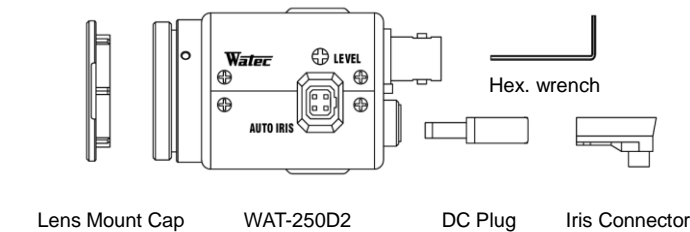

## Description of Parts

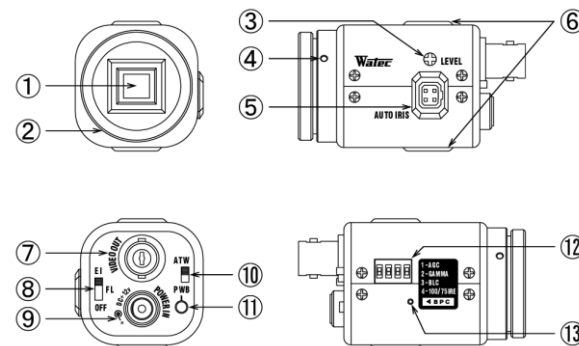

### ①CCD FRONT FACE

The light receiving face of the CCD camera (Dirt, water or oil deposits on the CCD will cause an unclear picture on the monitor. Attach the lens cap to protect the lens and the CCD from contamination and damage.)

### ②LENS MOUNT

Mount for the lens (CS-mount)

### ③IRIS LEVEL VOLUME

By controlling the volume, the iris level of the DC iris lens can be adjusted.

### ④FOCUSING ADJUSTMENT SCREWS

There are 3 hex. adjustment screws each placed at intervals of 120° for fine focusing of the lens.

### ⑤AUTO-IRIS SOCKET

This socket is for the video/DC auto-iris lens cable connector. (Video/DC: Auto selected by the camera)

### ⑥TRIPOD MOUNTING SCREW HOLES

Mounting holes for stands. The size of these threads are 1/4", 20 threads, 4.5±0.2mm, which is the same as any standard camera tripod (U1/4").

### ⑦VIDEO OUT (BNC)

The terminal for composite video signal output

### ⑧AE MODE CONTROL

The switch for the shutter mode control according to the object being monitored.

### ⑨POWER IN

The terminal designed for connection with the DC-plug of the power adaptor.

### ⑩WHITE BALANCE

The switch for selecting white balance mode.

### ⑪PUSH-LOCK WHITE BALANCE

The button for manual setting of the white balance if the white balance mode is set to PWB.

### ⑫FUNCTION SWITCHES

Functional switches for setting AGC, gamma control, BLC (Back light compensation) and video level.

### ⑬WHITE BLEMISH CORRECTION BUTTON

The button for correction of white blemish.

## Power Supply

Use a stabilized power adaptor designed for DC+12V±10%, with a current capacity of more than 250mA.

Use the optional DC plug if the shape or polarity of the DC plug of the power adaptor to be used is not compatible with the camera (See the drawing on the right).

The wiring on the connector must be exact. Be careful not to touch the other terminal while wiring. Protect the wiring portion by using insulation tape after wiring. If the above care and attention is not adhered to, damage to the WAT-250D2 and power adaptor may occur and may also cause fire.

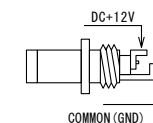

## Auto-iris Lens

Before connecting the auto-iris lens, please make sure that the pin configuration is correct by confirming with the following table. If the configuration of your iris connector is different from the following, the plug and pins will need to be rewired.

Pin No.	EIAJ Video Auto-iris Lens Arrangement	EIAJ DC Auto-iris Lens Arrangement
①	Power	Control -
②	Not used	Control +
③	Iris signals	Drive +
④	Common (GND)	Drive -

## Set-up and Operation

- Ensure that the power to the WAT-250D2 and the peripheral equipment is turned off before making any connections.
- Remove the lens mount cap from the WAT-250D2 and attach the CS-mount lens. Use the optional C-mount adaptor(30CMA-R) when a C-mount lens is used.
- Connect the iris control cable to ⑤AUTO-IRIS SOCKET on the WAT-250D2 when an auto-iris lens is being used.

- Connect ⑦VIDEO OUT on the WAT-250D2 with the monitor, using a coaxial cable with 75Ω impedance, such as an RG-59 or an RG-6/U. Select a monitor with the same television system as the WAT-250D2: NTSC or PAL. A monitor with more than 600TV lines is recommended.
- Insert the power plug of the power adaptor to ⑨POWER IN on the back panel of the WAT-250D2. Confirm that the power adaptor is not connected to the power supply before insertion of the power plug into ⑨POWER IN.
- Turn on the power to the WAT-250D2, monitor and all other allied equipment. When a picture cannot be obtained on the monitor, check and follow the procedure mentioned in the [Problems and Trouble Shooting] section.
- After following the procedure below and the picture is still out of focus, open the iris fully and loosen ④FOCUSING ADJUSTMENT SCREWS with the hex. wrench and move the lens forwards until a clear picture is obtained.

Manual Lens	Adjust the focus and iris to the best position on the lens.
Video Auto-iris Lens	Adjust the focus on the lens.
DC Auto-iris Lens	Adjust the iris level on the camera, then adjust the focus on the lens. See below.

### Iris Level Adjustment (for DC auto-iris lenses only)

Adjust ③IRIS LEVEL VOLUME placed on the side of the unit until an acceptable light level is attained. No change will occur if a video iris lens or manual iris lens is fitted.

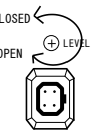

- Select any required shutter mode by the ⑧AE MODE CONTROL. (Shutter mode is set to EI upon shipment.)

AE Mode	Effect
EI	Automatically selects the shutter speed according to The lighting conditions, retaining the proper exposure mode. (Electronic Iris)
FL	Reduces the flickering phenomena occurring on the monitor screen caused by fluorescent or mercury lamps.
OFF	Fixes the shutter speed to NTSC1/60, PAL1/50.

※In EI mode, intense light may leave a trail on the screen longitude. This smearing is a natural phenomenon and is not due to equipment failure or fault.

- Adjust the required white balance settings by the ⑩WHITE BALANCE or ⑪PUSH-LOCK WHITE BALANCE. (White balance mode is set to ATW upon shipment.)

Mode	Effect
ATW	Automatically adjusts to the changing color temperature of the illumination.
PWB	Manually adjusted according to your requirement ⑪PUSH-LOCK WHITE BALANCE keep pressed until the required color temperature is acquired.

- Set the ⑫FUNCTION SWITCHES according to your requirements.

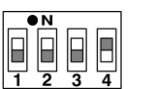

Switch	Setting	Effective Condition	Factory Settings
1. AGC	ON	When sensitivity is more important than the SN ratio	✓
	OFF	When SN ratio is more important than sensitivity, or when a stable lighting condition is present	
2. Gamma Correction	ON	Applicable to a general surveillance monitoring system	✓
	OFF	When gamma correction is not required for image processing	
3. BLC	ON	When the picture of the monitored object is silhouetted due to strong lighting from above or behind	✓
	OFF	When the illumination differences between a monitored object is narrow	
4. Video Level	ON [100]	When dark areas on an object with contrasting light and dark area are monitored	
	OFF [75]	When the standard video output level is required	✓

- 12) Correction of white blemish by ⑬WHITE BLEMISH CORRECTION BUTTON. The WAT-250D2 is manufactured using high-grade CCD devices that are selected by tough standards by the manufacturer. However, it is impossible to prevent the white blemishes from occurring after shipment because the white blemish phenomena can be caused by cosmic rays. The WAT-250D2 has a white blemish correction circuit to help control the white blemish phenomena. Correct according to the following procedures, if white blemishes are present.

**[PROCEDURE]**

1. Completely cover the lens to prevent light entering.
2. Set to PWB by ⑩WHITE BALANCE
3. Set to AGC ON by ⑫FUNCTION SWITCHES
4. Press the ⑬WHITE BLEMISH CORRECTION BUTTON using a fine stick.
5. After 5 seconds, the white blemishes are automatically detected, and then recorded to the camera.

※Make sure that the lens is completely shielded from light before correction of the white blemishes. If the lens is not covered properly and light can enter into the lens on to the CCD face, the correction of the white blemish may not be detected correctly.

※Make sure that ⑩WHITE BALANCE "PWB" is selected. If ATW position is selected; the data cannot be saved to the camera.

## Contact information

- Design and specifications are subject to change without notice.
- Watec is not responsible for any inconvenience or the attendant damages to the video and monitoring recording equipment caused by misuse, mis-operation or improper wiring of our equipment.
- If for any reason the WAT-250D2 does not work properly, or if you have any questions regarding installation or operation, please contact the distributor or dealer from which it was purchased.

### Contact information

***Watec*** Watec Co., Ltd.

Add.: 254-2 Nihonkoku, Daihoji, Tsuruoka- Shi,  
Yamagata-Ken, 997-0017 Japan  
TEL: +81-235-23-4400 FAX: +81-235-23-4409  
E-mail: info-o@watec.co.jp  
URL: <http://www.watec.co.jp>

1483Z00-Y2000005

## Options

To purchase these options, please contact the distributor or dealer from which you purchased the WAT-250D2.



### **C-mount Adaptor (30CMA-R)**

This lens mount adaptor is used to convert a CS-mount to a C-mount.



### **Mini Stand (MS50)**

A convenient stand for the WAT-250D2. With this stand, the camera can be adjusted to any desired angle.